

Rural Water Tank Specifications

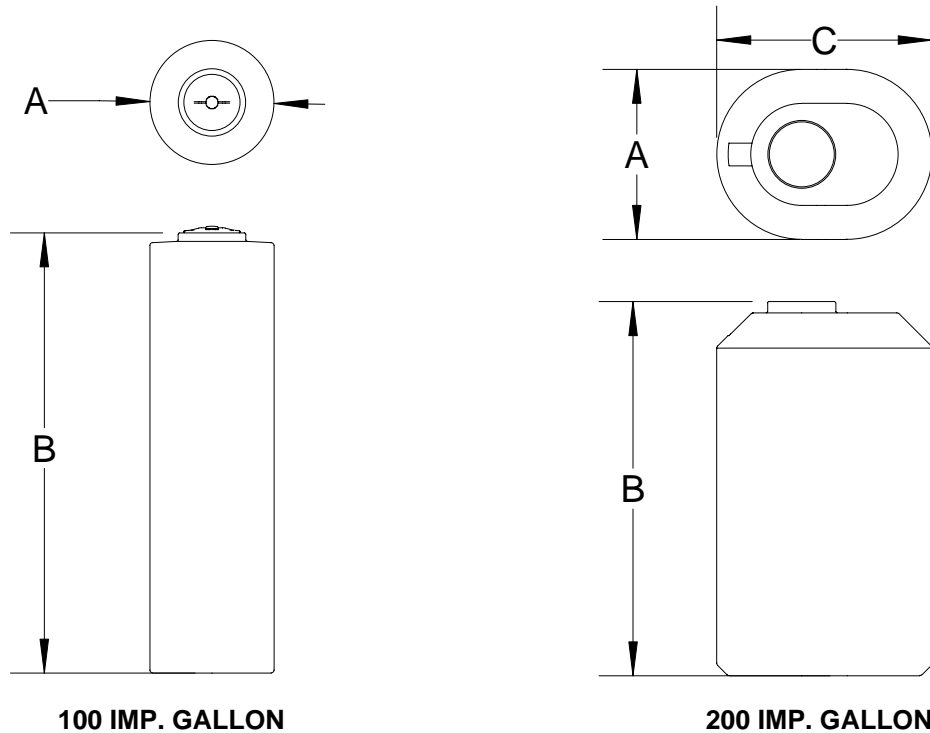

CAPACITY		SPECIFICATIONS				
IMP. GALS.	U.S. GALS.	DIMENSION A	DIMENSION B	DIMENSION C	LID SIZE	STANDARD FITTING
200	240	30"	66"	38"	8"	3/4"
100	120	22"	78"	N/A	8"	3/4"

FEATURES:

- All tanks have UV8 protection to prevent deterioration from sunlight.
- All tanks come standard with 8" vented lid, bulkhead fitting and interior siphon tube for more complete drainage.
- Optional brass float valve available.
- All tanks are available in translucent white or black. (Black eliminates algae formation.)
- Sight gauges available to allow product visibility in black tanks.
- All tanks are potable and manufactured from materials that meet FDA Regulations 21 CFR 177.1520 and may be used to contain materials for human consumption.
- These are Standard duty tanks which are typically used to contain liquids with densities up to 14 lbs. per gal.
- Standard duty tanks carry a three (3) year warranty against defects in workmanship.