

Elliptical Tank Specifications

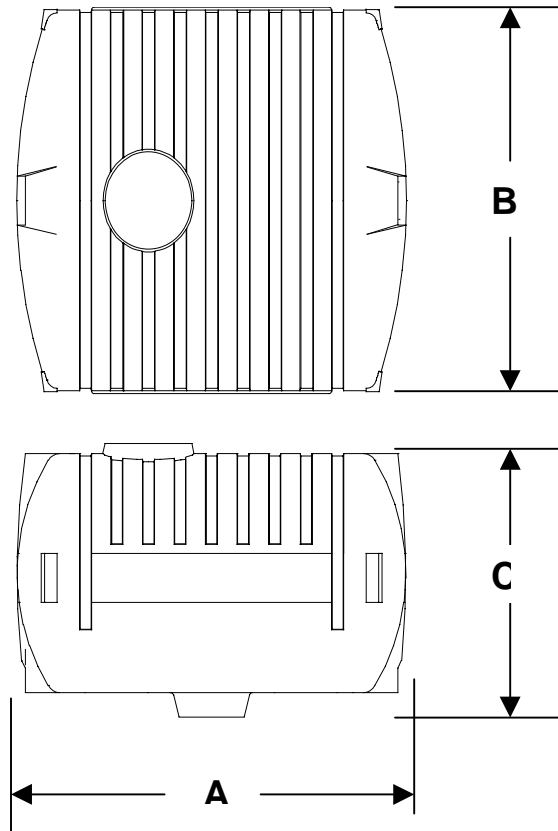

CAPACITY		SPECIFICATIONS				
IMP.	U.S.	DIMENSION	DIMENSION	DIMENSION	LID	STANDARD
GALS.	GALS.	A	B	C	SIZE	FITTING
1600	1920	89"	91"	87"	16"	2"HD
833	1000	90"	79"	52"	16"	2"HD
540	648	90"	60"	46"	16"	2"HD

*Dimension C does not include the sump

FEATURES:

- All tanks have UV8 protection to prevent deterioration from sunlight.
- All tanks come standard with 16" vented lid, gallonage indicator, bulkhead fitting.
- All tanks are available in translucent white or black. (Black eliminates algae formation.)
- All tanks are potable and manufactured from materials that meet FDA Regulations 21 CFR 177.1520 and may be used to contain materials for human consumption.
- All tanks are typically used to contain liquids with densities up to 14 lbs. per gallon.
- These tanks carry a one (1) year warranty against defects in workmanship.
- 1600 gallon tank available only in heavy duty for liquids up to 19 lbs. per gallon