

1750 Imperial Gallon Vertical Tank

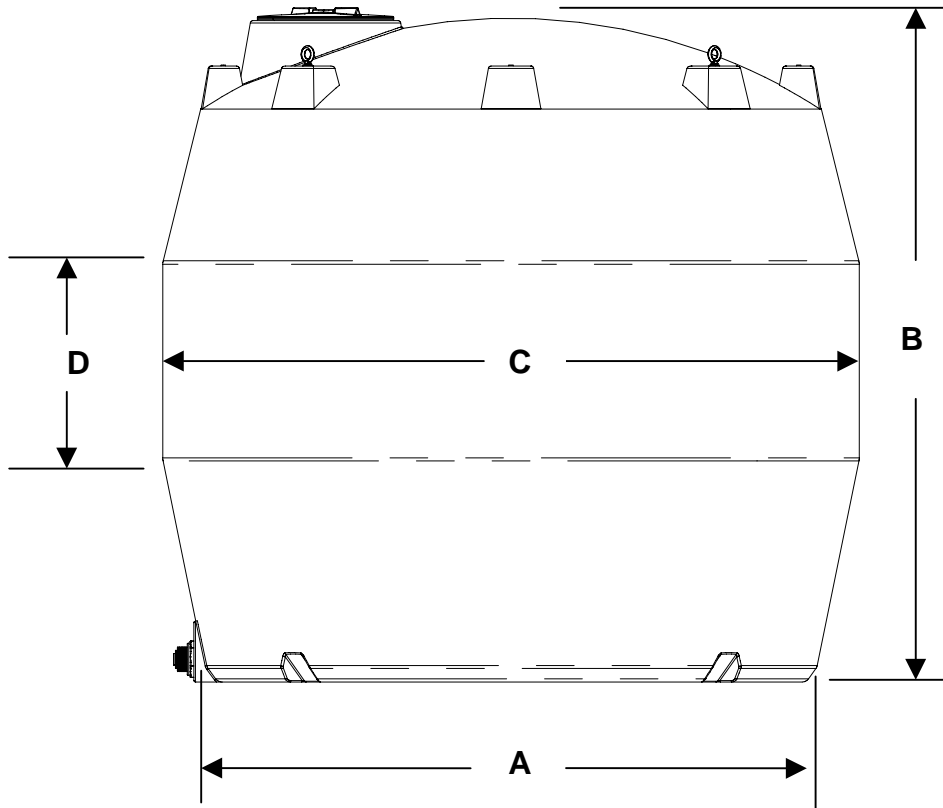

CAPACITY		SPECIFICATIONS					
IMP. GALS.	U.S. GALS.	DIMENSION A	DIMENSION B	DIMENSION C	DIMENSION D	LID SIZE	STANDARD FITTING
1750	2100	80"	88"	92"	26"	16"	2"HD

FEATURES:

- All tanks have UV8 protection to prevent deterioration from sunlight.
- All tanks come standard with tie down lugs, 16" vented lid, gallonage indicator, bulkhead fitting and interior siphon tube for more complete drainage.
- Optional 3" heavy-duty bulkhead fitting is available.
- All tanks are available in translucent white or black. (Black eliminates algae formation.)
- Sight gauges available to allow product visibility in black tanks.
- All tanks are potable and manufactured from materials that meet FDA Regulations 21 CFR 177.1520 and may be used to contain materials for human consumption.
- Heavy duty tanks are typically used to contain liquids with densities up to 19 lbs. per gallon.
- Standard duty tanks are typically used to contain liquids with densities up to 14 lbs. per gal.
- Heavy-duty tanks carry a five (5) year warranty against defects in workmanship.
- Standard duty tanks carry a three (3) year warranty against defects in workmanship.